

# Specifications

# LE 13 GT

**TEUPEN**<sup>®</sup>  
...access redefined

## PERFORMANCE

Working height, max.	12,75 m
Horizontal outreach with 200 kg	6,05 m
Up and Over Clearance, max.	4,60 m
Basket capacity	200 kg
Movable jib	-
Turret rotation	355°
To be jacked up on ground slope of	10°/17,5 %
Height and width track adjustment	-
Gradeability, max.	14,4°/25,5 %
Slope angle	14,4°/25,5 %
Travel speed	1,0 km/h

## MEASUREMENTS

Platform height (A)	1,10 m
Platform length (B)	0,70 m
Platform width (C)	1,40 m
Length, overall (D)	4,75 m
Length without basket (E)	4,00 m
Height, travel position (F)	1,99 m
Width, minimal overall width (G)	0,78 m
Ground clearance, max. (H)	0,40 m
Track (L x W) (I)	118 x 18 cm
Length outrigger footprint, max. (J)	3,69 m
Width outrigger footprint, max. (K)	2,86 m
Outrigger plate Ø	0,18 m

## WEIGHT

Total weight	1400 kg
Live load in travelling position	4,27 kN/m <sup>2</sup>
Live load in working position	1,75 kN/m <sup>2</sup>
Point load per outrigger plate, max.	11,70 kN

## POWER

Standard power source	<b>1) Electric:</b> 230 V, 12,9 A, 2,2 kW
Optional power sources	<b>1) Generator:</b> external <b>2) Petrol:</b> Robin-Subaru EX21 (3,7 kW/5 hp) <b>3) Diesel:</b> Hatz 1B30 (5,4 kW/7,2 hp)
Fuel tank capacity petrol engine	3,6 l
Fuel tank capacity Diesel engine	5,0 l

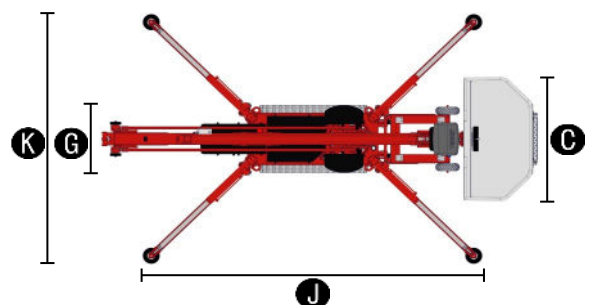
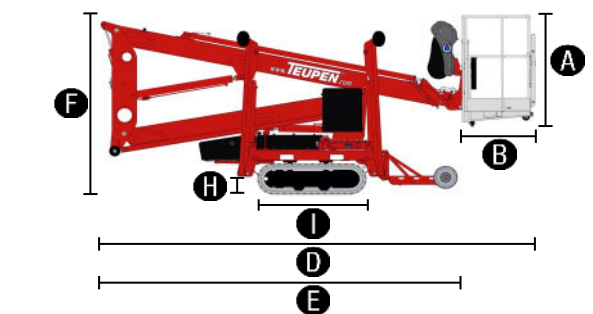
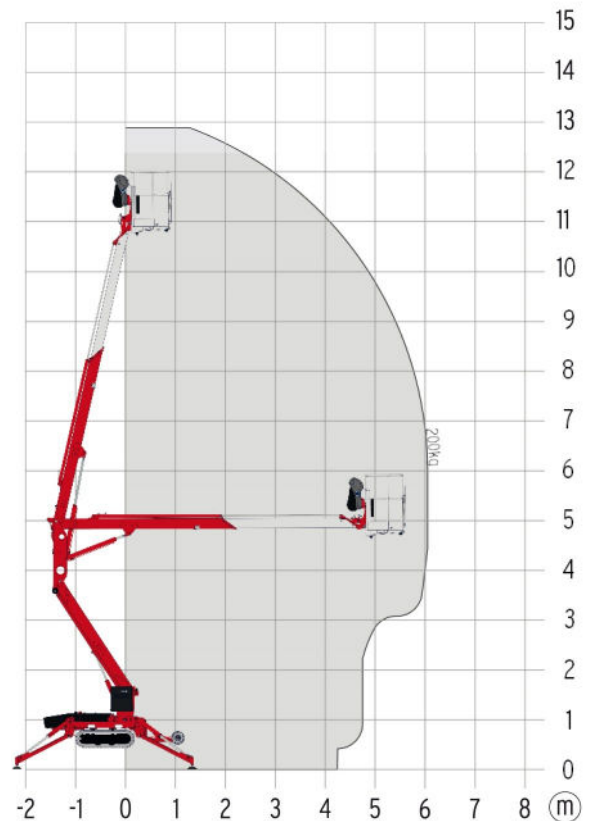

## STANDARDS COMPLIANCE

2006/42/EC-Machinery directive  
(Harmonised standard EN280:2001 + A2:2009); 2004/108/EC (EMC);  
2000/14/EC (Noise emission directive - outdoor)

www.**TEUPEN**.com

# Features

# LEO 13 GT

**TEUPEN**<sup>®</sup>  
...access redefined

## CHASSIS

- Powerful track drive for precise maneuvering and terrainability
- White, non-marking rubber tracks with specially arranged profile providing optimum grip

## STABILISATION

- Fully-hydraulic, automatic levelling system
- Constant outrigger setup monitoring with ground pressure sensing
- Wear resistant, anti-friction PVC outrigger feet

## BOOM SYSTEM

- Removable cable remote control
- All functions are available from one control panel
- Electric-proportional controls with intuitive operator guidance
- Robust, lockable control panel cover
- Self-levelling platform with fully-hydraulic levelling system
- Boom rotation via high-performance slew ring, worm gear and hydraulic motor
- Detachable two-person basket with eyelets for safety harnesses
- Emergency lowering system via hand pump
- 355° turntable rotation

## POWER

- 230 V Electric Motor (EU)
- Detachable cart for external generator

## PRODUCTIVITY, SAFETY, QUALITY

- Sturdy base frame with full length forklift pockets
- 230 V (EU) power outlet in the basket
- High-quality paint in RAL 3020 (red)
- Drive operation without basket available
- Cables and hoses are safely routed through the boom structure
- Biodegradable hydraulic oil
- Lock valves - hydraulic return valves directly on all hydraulic cylinders
- Relief valves protecting the hydraulic system from too high pressures
- Protective covers for oil-tank, emergency controls and connecting cables and hoses
- Protective covers for electric housing and ground control panel
- Hour meter
- Fuzzy IV control technology

## OPTIONS

- Hatz 1B30 Diesel engine (5,4 kW/7,3 hp). This option can not be combined with the petrol engine or generator.
- Robin Subaru EX21 petrol engine (3,7 kW/5 hp) incl. mount and cover. This option can not be combined with the Diesel engine or generator.
- Custom paintwork, one colour, according to RAL scheme (except metallic coatings, signal- or special colors)
- Custom paintwork, two colours, according to RAL scheme (except metallic coatings, signal- or special colors)
- Generator Endress with start-stopp device  
This option can not be combined with the combustion engine.

## ACCESSORIES

- Safety harness
- Outrigger pad (450 x 400 x 40 mm)
- Lockable storage frame for outrigger pads (additional weight: approx. 4 kg)
- 4 outrigger/sliding pads (700 x 220 x 60 mm)
- Track mat (2000 x 800 x 15 mm)
- Lifting device (200 kg load capacity). This option can only be ordered in combination with the mounting for the lifting device.
- Mounting for lifting device
- 4 covers on piston rod (outrigger/stabiliser) cylinders

## TRAILERS

- Tandem Low Platform trailer (aluminium) including 4 tension belts (length 3,50 m)  
Permissible total weight: 3000 kg  
Tandem rubber-sprung axle: 3000 kg  
Net weight: approx. 440 kg  
Wheels 155/70/R12 ET20  
Lighting fitting according to EU directives
- Tandem Low Platform trailer (steel) including 4 tension belts (length 5,30 m)  
Permissible total weight: 3000 kg  
Tandem rubber-sprung axle: 3000 kg  
Net weight: approx. 476 kg  
Wheels 185 R14 C8  
Lighting fitting according to EU directives

## CONTACT

**Teupen Maschinenbau GmbH**  
Marie-Curie-Str. 13  
48599 Gronau  
Germany

phone +49 (0) 2562 8161-0  
fax +49 (0) 2562 8161-888  
mail@teupen.com

Version 2016-B. Product specifications are subject to change without notice or obligation. Photographs and drawings in this document are for illustrative purposes only. Refer to the appropriate Operator's Manual for instructions on the proper use of this equipment. Failure to follow the appropriate Operator's Manual when using our equipment or to otherwise act irresponsibly may result in serious injury or death. The only warranty applicable to our equipment is the standard written warranty applicable to the particular product and sale and we make no other warranty, expressed or implied. Products and services listed may be trademarks, service marks or trade-names of Teupen Maschinenbau GmbH and/or its subsidiaries in the U.S.A. and many other countries. "Teupen", "Access redefined" and "LEO Series" are registered Trademarks of Teupen GmbH in the United States of America and many other countries. © 2016 Teupen Maschinenbau GmbH.

